

Oil debris sensor kit



Key Features

- No Moving Parts
- High Temperature Operation
- Easy Replacement of Standard Plug
- Thermally Stable
- Compact
- Lightweight

The Oil Debris Sensor is designed to replace a conventional magnetic oil plug or sump plug in Motorsport transmission or engine applications. Its low height profile eliminates changes to close-fitting bodywork or adverse effects in aero performance of the vehicle.

The sensor works by attracting metallic debris to the face of the sensor just like any other conventional plug but with the added ability to measure the particle build-up remotely and subsequently provide the user with a dynamic 'health check' of the engine or transmission.

The sensor uses a remotely sited electronic module connected by a screened harness to the plug. The sensor can be operated in oil temperatures of up to 180°C for continuous periods. A function to zero the measurement start position (representing a clean plug condition) can be accessed via RS232.

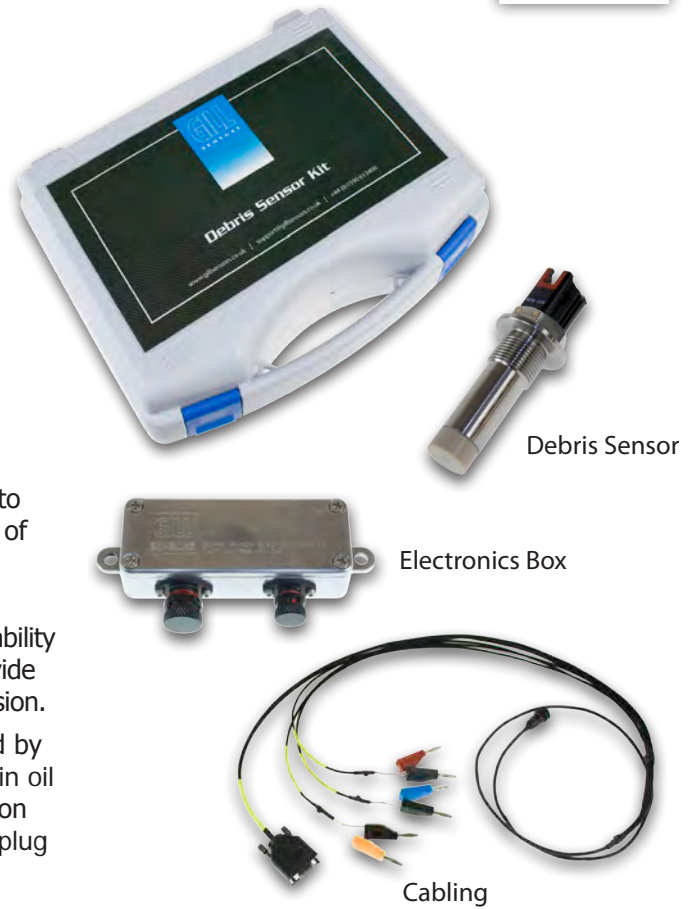

Specification

Electrical

Supply Voltage	+4.5VDC to +32VDC
Over Voltage Protection	>31VDC
Supply Current	<10mA
Reverse Polarity Protection	to -30VDC
Resolution	10 bit
Sample Rate	10Hz
Zero Tare Function	Accessible via RS232
Onboard Integrity Test Function	Yes

Analogue Output

Channel 1	2.25V - 4.25V Fine Measurement (Plug F)
Channel 2	0.5V - 4.25V Coarse Measurement (Plug I)
Error Indication	4.5V (Channel 1 & 2)

Connections

Wiring	Raychem Type 55 / Screened 26 AWG or customer specified
Connector	Deutsch ASC 1 05-06-SN or customer specified

Mechanical

Size	41mm x ø22.25mm
Mounting	M14 x 1.0 Thread (or customer specified)
Weight	from only 25g
Sensor Materials	Titanium, PEEK, H30

Environmental

Protection Class	IP68
Operational Temperature	-40°C to +180°C
EMC Immunity Level	SAE J1113/2 1996 design guideline
Vibration	15g RMS (24-2000Hz) & SAE J1455 design guidelines used
Finish	Anodised to DEF STAN 025
Compatible Medium	Petroleum, Oils, General Automotive Fluids

Engine/Transmission Wear Debris Detection

Oil debris sensor kit

Twin Channel Debris Detection

Gill not only measures the debris build up to the face of the sensor but also quantifies the type of debris, whether this is fine dust particles or larger debris objects (usually the result of internal mechanical damage). The information is obtained via two independent analogue channels, therefore combinations of debris can be determined enabling the user to (potentially) predict a failure so that the option of corrective action may be taken.

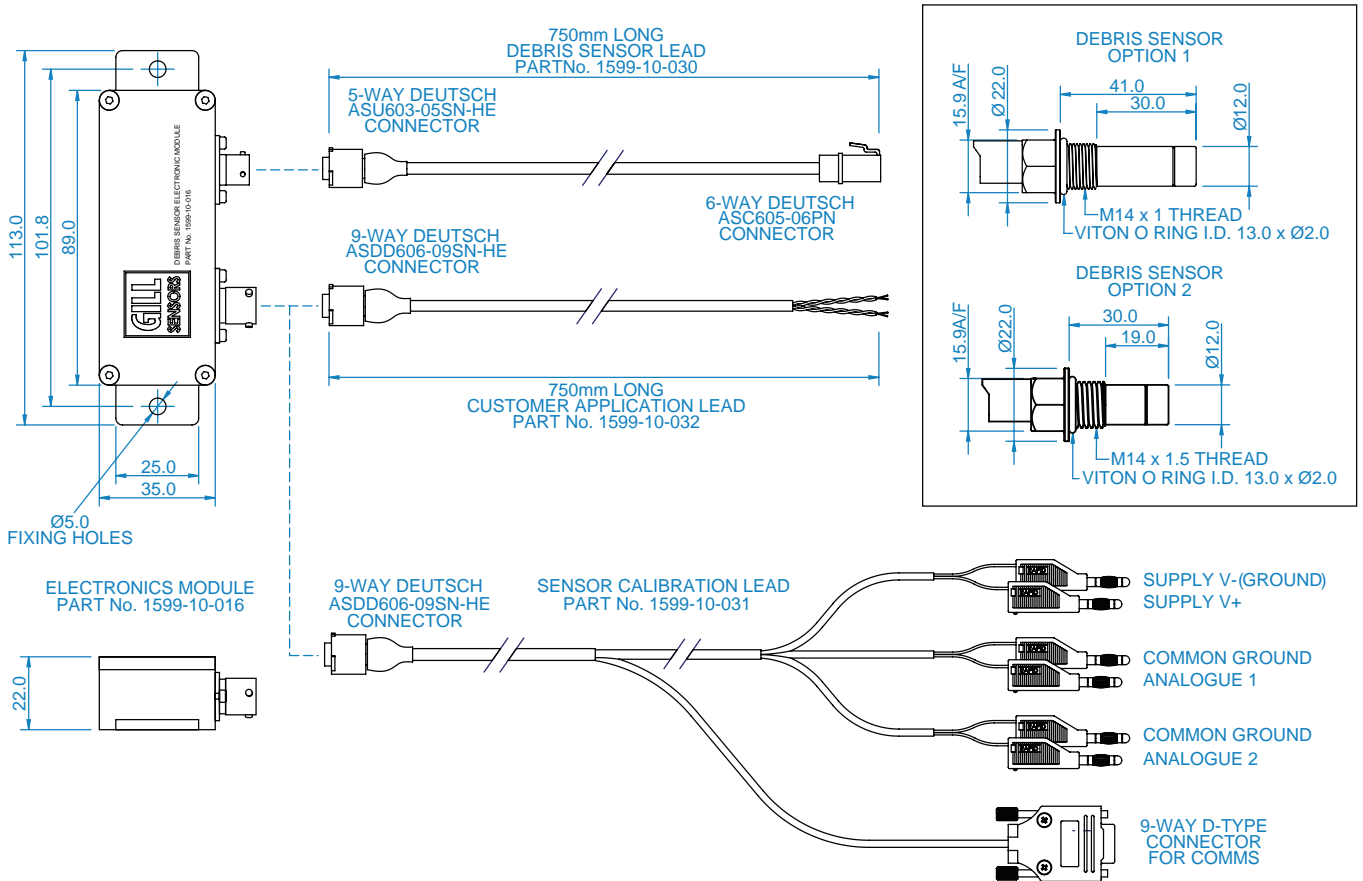

Gill Sensors
Saltmarsh Park
67 Gosport Street
Lymington
Hampshire
SO41 9EG, UK

T: +44 (0) 1590 613 400
F: +44 (0) 1590 613 401
E: info@gillsensors.co.uk

www.gillsensors.co.uk



Copyright © Gill Sensors 2011
CD1599-K - Iss 2
Gill Research & Development Ltd
Reg No. 3154453 Registered Office: The George Business Centre, Christchurch Road, New Milton, BH25 6QJ