

Rxl™ Stainless-Steel Liquid Level Sensor



Key Features

- SAE 5-Bolt Flange Mount with Tube Support
- Stainless-Steel Construction
- Available up to 1500mm Long
- 0-5V Analogue Output (configurable)
- Suitable for use with Aggressive or Corrosive Liquids.
- -40°C to +125°C Operating Temperature
- Factory Calibrated
- Solid-State Capacitive Technology

The Rxl stainless-steel liquid level sensor is available up to 1500mm long, designed specifically for applications where monitoring of corrosive fluids is required, or where specific materials compatibility standards must be met (often experienced in medical and food processing industries).

The sensor features an SAE 5-bolt mounting pattern, with mechanical strengthening features on the underside of the flange to support the longer sensor probe length.

The Rxl utilises capacitive technology, with fully integrated electronics providing a fully configurable 0-5V analogue output over the calibrated sensing range. Each sensor is factory calibrated in the specified liquid type (or equivalent), and is provided with free software to allow re-calibration at any time by the user.



RoHS
Compliant

Electrical

Supply Voltage	+6VDC to +24VDC
Supply Current	<10mA @12V
Serial Interface	RS232 (+5V)
Resolution	10 bit
Sample Rate	10Hz, 40Hz & 80Hz

Analogue Output

Voltage Output Range	0.25V - 4.75V over sensing range
Range Accuracy	±1% of medium depth @20°C

Wiring

Wire	0.5m flying lead unless specified
Wiring Gauge	Typically 26 AWG Raychem type SS (options up to 20 AWG if requested)
Cable Material Compatibility	Wiring sleeved with either Fluoroelastomer or Raychem DR25, or customised to customer specifications

Mechanical

Probe Length	80 - 1500mm (customer to specify)
Mounting	SAE 5-bolt pattern
Weight	From 300g (dependant on length)

Environmental





Protection Class	IP67
Operational Temperature	-40°C to +125°C
EMC Immunity Level	SAE J1113/2 1996
Main Construction	Stainless-steel

Compatible Medium

Fuel	Gasoline, Unleaded, LRP
Oil	Engine oils, transmission oils, steering & hydraulic fluids Diesel Heavy Oil
BioFuel	Ethanol E100, E85, E50, E10 Methanol
Other	Salt water, Coolant, Acids. Please consult Gill for other liquid compatibilities

Rxl™ Stainless-Steel Liquid Level Sensor

Wiring

	Red	V+ (Power)
	Black	V- (GND)
	Orange	Analogue signal 0.25V to 4.25V
	Green	Serial Rx
	White	Serial Tx

Part Number

1612-00-019

Dimensions X & Y are customer specified

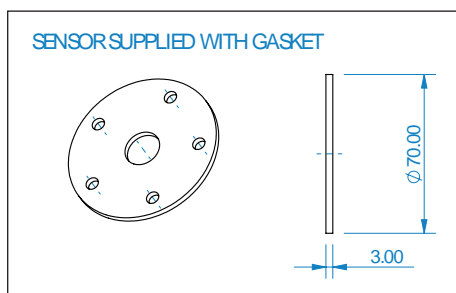
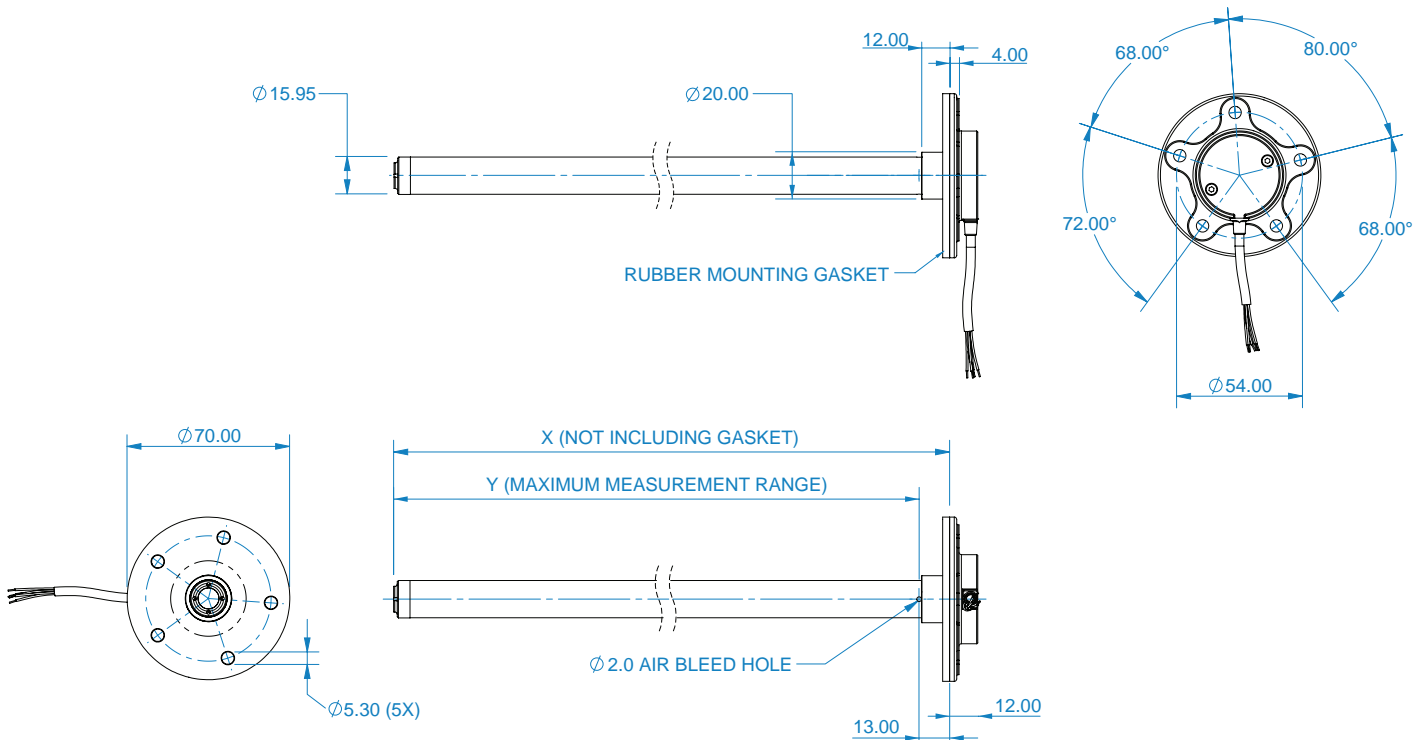

Gill Sensors
Saltmarsh Park
67 Gosport Street
Lymington
Hampshire
SO41 9EG, UK

T: +44 (0) 1590 613 400
F: +44 (0) 1590 613 401
E: info@gillsensors.co.uk

www.gillsensors.co.uk



Copyright © Gill Sensors 2011
LD1612-04 - Iss 1
Gill Research & Development Ltd
Reg No. 3154453 Registered Office: The George Business Centre, Christchurch Road, New Milton, BH25 6QJ