

Liquid Level Sensor



Key Features

- SAE 5-bolt flange mount with Tube Support
- Aluminium construction
- Available up to 1500mm long
- Suitable for use with fuels, oils and bio-fuels
- 0-5V analogue output
- -40°C to +125°C operating temperature
- Factory calibrated
- Solid-State Capacitive Technology

The Rxl liquid level sensor is a solid-state capacitive device, constructed from aluminium and available up to 1500mm long (manufactured to your length requirement).

The SAE 5-bolt mounting pattern includes extra mechanical strengthening features on the underside of the mounting flange to support longer sensor lengths.

The sensor features fully integrated electronics, providing a configurable 0-5V analogue output over the sensing range (typically calibrated 0.25V empty, 4.75V full). The sensor is factory calibrated in your liquid type (or equivalent) and provided with free software to allow re-calibration of the sensor if required.



Optional Support Boss



Electrical

Supply Voltage	+6VDC to +24VDC
Supply Current	<10mA @12V
Serial Interface	RS232 (+5V)
Resolution	10 bit
Sample Rate	10Hz, 40Hz & 80Hz

Analogue Output

Voltage Output Range	0.25V - 4.75V over sensing range
Range Accuracy	±1% of medium depth @20°C

Wiring

Wire	0.5m flying lead unless specified
Wiring Gauge	Typically 26 AWG Raychem type SS (options up to 20 AWG if requested)
Cable Material Compatibility	Wiring sleeved with either Fluoroelastomer or Raychem DR25, or customised to customer specifications

Mechanical

Probe Length	80 - 1500mm (customer to specify)
Mounting	SAE 5-bolt pattern
Weight	From 200g (dependant on length)

Environmental





Protection Class	IP67
Operational Temperature	-40°C to +125°C
EMC Immunity Level	SAE J1113/2 1996
Main Construction	Aluminium
Finish	Anodised to DEF STAN 025

Compatible Medium

Fuel	Gasoline, Unleaded, LRP
Oil	Engine oils, transmission oils, steering & hydraulic fluids, Diesel Heavy Oil
BioFuel	Ethanol E100, E85, E50, E10 Methanol
Other	Please consult Gill if you have another fuel requirement

Liquid Level Sensor

Wiring

	Red	V+ (Power)
	Black	V- (GND)
	Orange	Analogue signal 0.25V to 4.25V
	Green	Serial Rx
	White	Serial Tx

Part Numbers

Fuel	1612-00-021
Oil	1612-00-022
Bio-Fuel	1612-00-023

Dimensions X & Y are customer specified

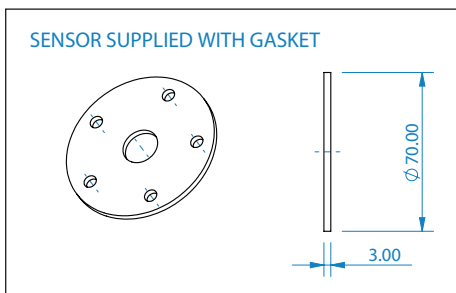
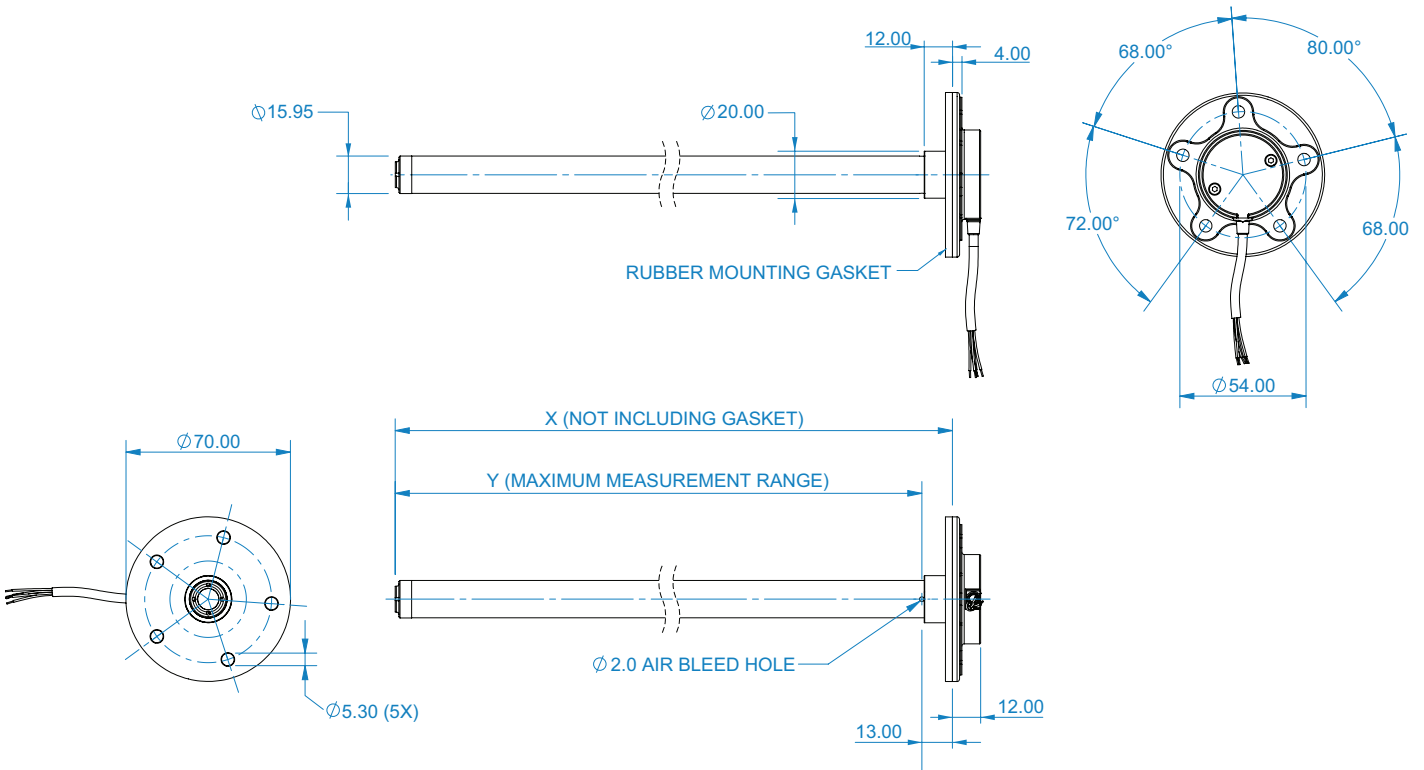

Gill Sensors
 Saltmarsh Park
 67 Gosport Street
 Lymington
 Hampshire
 SO41 9EG, UK

T: +44 (0) 1590 613 400
 F: +44 (0) 1590 613 401
 E: info@gillsensors.co.uk

www.gillsensors.co.uk

