

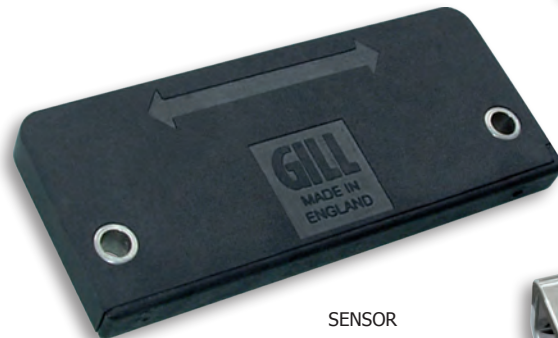

Key Features

- Non-Contact
- No Moving Sensor Parts
- Up to 60mm Linear Measurement
- Up to 90° Angular Measurement
- Fully Configurable Range
- Analogue/Digital Output
- Unlimited Mechanical Life
- Submersible



SENSOR

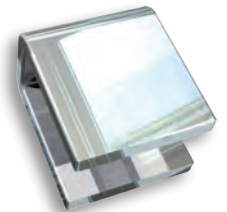

ACTIVATOR

The Blade60 Position Sensor accurately senses the linear or angular position of a metallic 'activator' mounted away from the face of the sensor. The unique non-contact two-part design utilises Gill's patented inductive technology to provide a reliable, accurate output that will not deteriorate through use.

Small, light and robust, the sensor is fully electronic with on-board processing. The supplied software facilitates a fully configurable measurement range. Output signals are provided in three different formats and diagnostic information is given to assist in system fail-safe functionality.

At just 6mm thick installation is simple. Accuracy and durability are increased with the absence of mechanical linkages and the U-shaped activator can be formed as part of your application for minimum installation overhead. The sensor is available in standard and high-temperature formats and is available with standard or custom requested wiring options. Sealed to IP67, this sensor is ideal for a variety of applications where grime, moisture, temperature and vibration can have an adverse affect on other types of sensor.



SIDE VIEW OF SENSOR/ACTIVATOR CONFIGURATION



Electrical

Supply Voltage	+4.8 VDC to +30 VDC
Over Voltage Protection	>31 VDC
Supply Current	<10mA with comms
Reverse Polarity Protection	up to -30 VDC
Resolution	10 bit over configured range
Sample Rate	1KHz
Rise Time	2ms*
Pulse Energy Absorption	1.0J

Analogue Output

Measuring Range	Linear: ±30mm (configurable) Rotary: ±45° (configurable)
Voltage Output Range	0-4.2 V
Range Accuracy	±0.1mm or equivalent

PWM Output

Measuring Range	Linear: ±30mm (configurable) Rotary: ±45° (configurable)
Frequency	250Hz or 1KHz

Serial Output

Data Type	RS232 19.2K 8N
-----------	----------------

Switch Output

Type	Switch to GND 30 VDC Max, 8mA
------	-------------------------------

Mechanical

Size	6 x 77 x 32.5mm (DxWxL)
Sensor-Activator Clearance	0.5-2mm
Mounting	2 x Ø4mm holes on a 65.5mm pitch
Weight	25.6 grams (0.90 ounces) excluding cable
Activator Materials	See notes overleaf
Materials Compatibility	Water, engine oil, engine coolant, diesel fuel, gasoline, salt spray, degreaser, degreaser tsp, ammonia and dust. All common automotive liquids and materials

Environmental

Protection Class	IP67
Operational Temperature	-40°C to +85°C (standard) -40°C to +125°C (optional)
Dither Life	Non-contact: no deterioration through use

Options

Wiring	- Standard (30/28AWG) 85°C/125°C - Heavy duty (24AWG) 85°C/125°C - Customer specified
--------	---

*The sensor samples the position at 1ms intervals. Each sample is processed then made available via an analogue filter with a rise time of 1.5ms. The total delay to 50% output is approximately 2ms.

Non-Contact Position Sensor

Activator Options

- Tinned steel
- EN3B painted mild steel or similar
- Plastic/Copper Foil
- Others compatible, contact Gill with your requirement.

Blade60 Sensor Options

- 30 AWG 6 wire version (85°C max)
Part No:1508-00-006
- 28 AWG 6 wire version (125°C max)
Part No:1508-00-010
- 24 AWG 6 wire (125°C max)
Part No:1508-00-026
- Demo Kit
Part No: 1508DK
- Tinned mild steel activator
Part No:1484-30-050

Wiring

	Red	+4.8VDC to +30VDC Supply
	Black	System & Power Ground (GND)
	Blue	Switch Output
	Green	Serial Comms Input (Rx), RS232 Compatible
	White	Serial Comms Output (Tx), RS232 Compatible
	Yellow	Analogue Output: Voltage or PWM

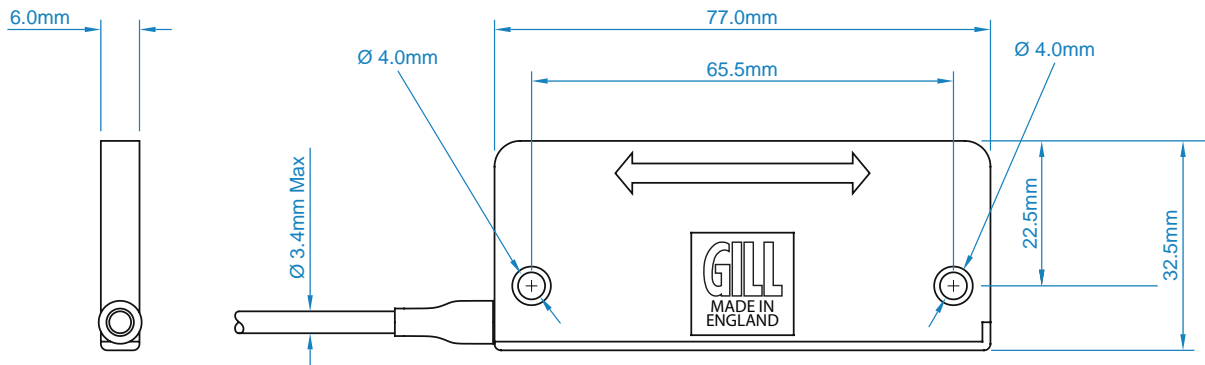

Model shown
Part no: 1508-00-006

Activator

The sensor requires a metallic activator to be mounted 0.5-2mm away from the sensing face. This can either be mechanically mounted to the moving object or machined into the application for minimal installation overhead. Below is a drawing showing the dimensions of our recommended standard activator. Please consult Gill for more information on activator design.

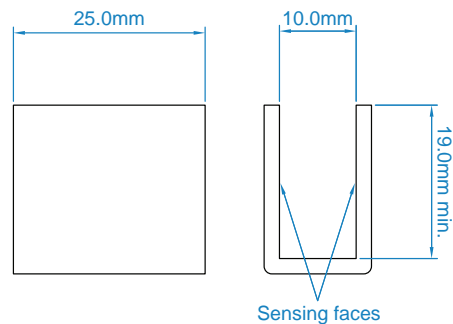

*All undefined dimensions are non-critical



Gill Sensors
Saltmarsh Park
67 Gosport Street
Lymington
Hampshire
SO41 9EG, UK

T: +44 (0) 1590 613 400
F: +44 (0) 1590 613 401
E: info@gillsensors.co.uk

www.gillsensors.co.uk

